

REV.	REVISION DESCRIPTION	DATE	CHKD.

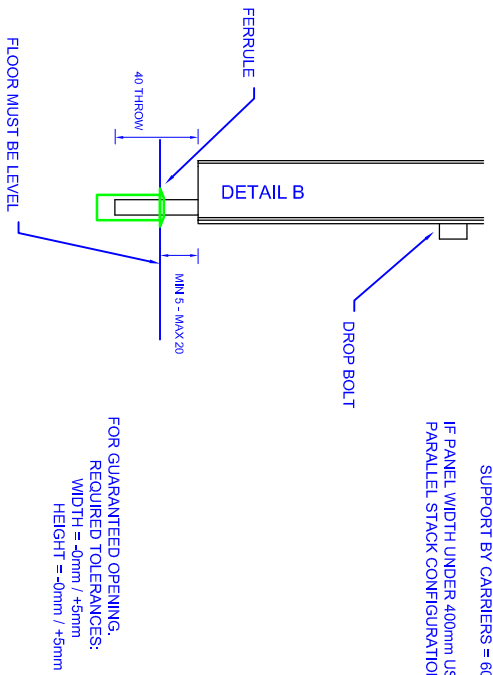
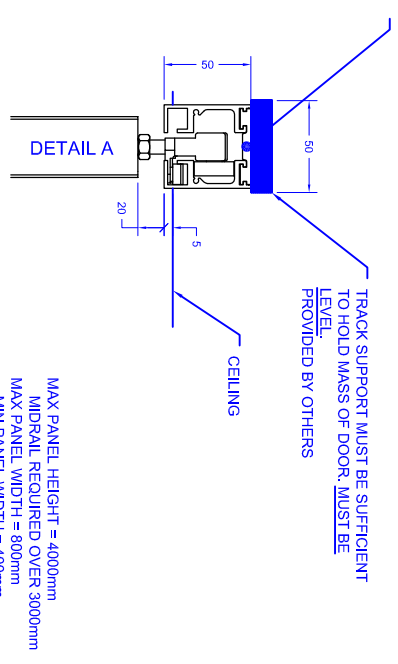
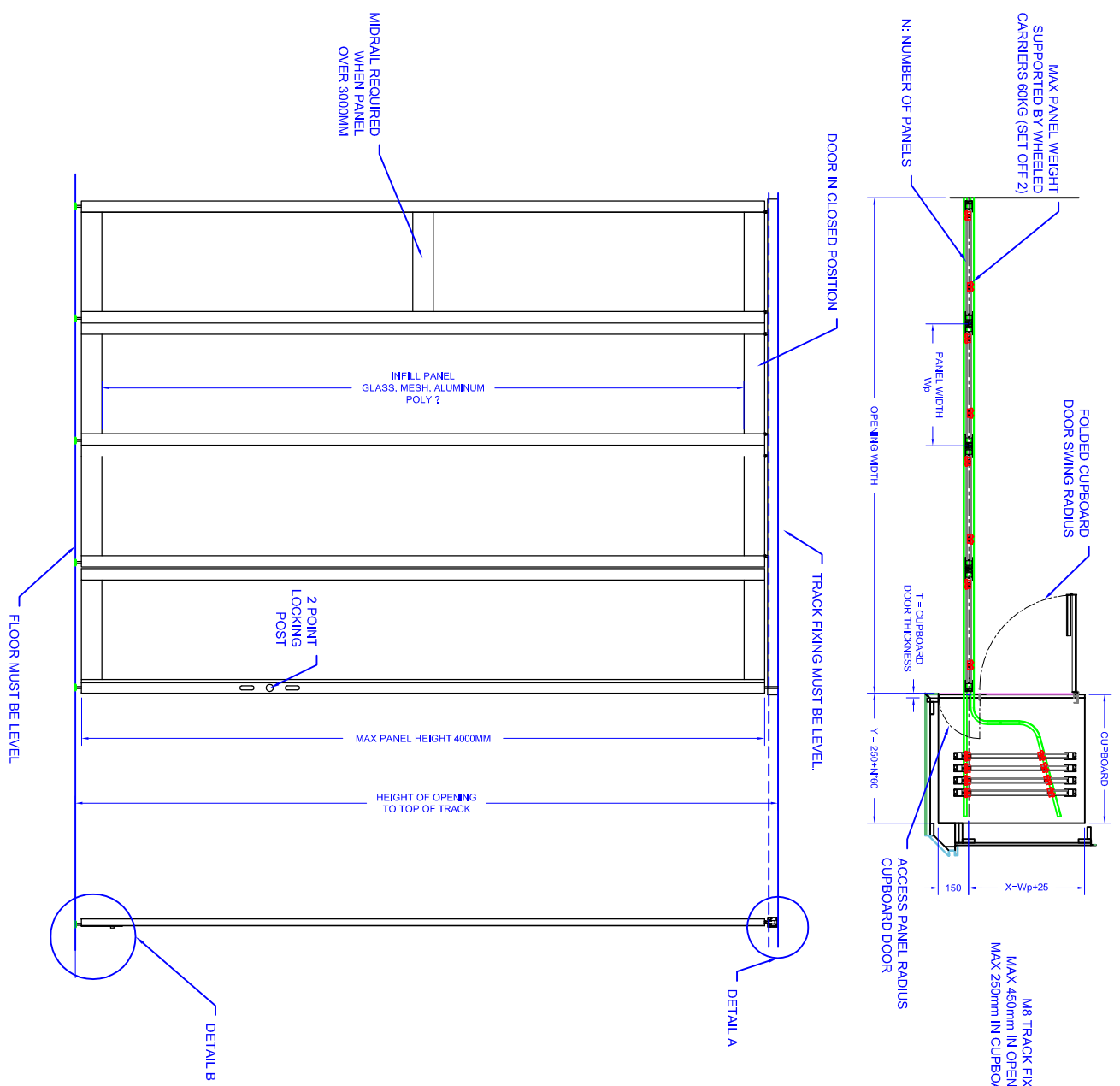

"FOR FURTHER INFORMATION CONTACT
MIRAGE ENGINEERING STAFF"

U.O.S. DIMENSIONS IN MILLIMETRES

CONFIDENTIAL NOTE: This drawing and its designs, specifications and engineering information disclosed hereon are the property of Mirage Doors (Aust) Pty Ltd and are not to be disseminated or reproduced without express written consent. The drawing is loaned in confidence and then only for consideration of the matter disclosed hereon. In accepting loan of this drawing, the recipient agrees to keep it and the matter disclosed hereon in confidence and not to use nor permit their use in any way detrimental to Mirage Doors (Aust) Pty Ltd.

Mirage Doors (Aust) Pty Ltd		PROJECT	FLESTA
ACN 601 182 629	PH 1 800 465 599	TITLE	STACKING DOORS
DATE 08/03/2016	DRAWN J.R.	SCALE	NTS
APPROVED & DATE	CHECKED	SIZE	DRAWING NO.
FILE FILENAME.dwg		A3	QLD-
		REV.	SHEET
		0	1/2

REV.	REVISION DESCRIPTION	DATE	CHKD.

MAX PANEL HEIGHT = 4000mm
 MIDRAIL REQUIRED OVER 3000mm
 MAX PANEL WIDTH = 800mm
 MIN PANEL WIDTH = 400mm
 MAX PANEL WEIGHT
 SUPPORT BY CARRIERS = 60KG
 IF PANEL WIDTH UNDER 400mm USE A
 PARALLEL STACK CONFIGURATION

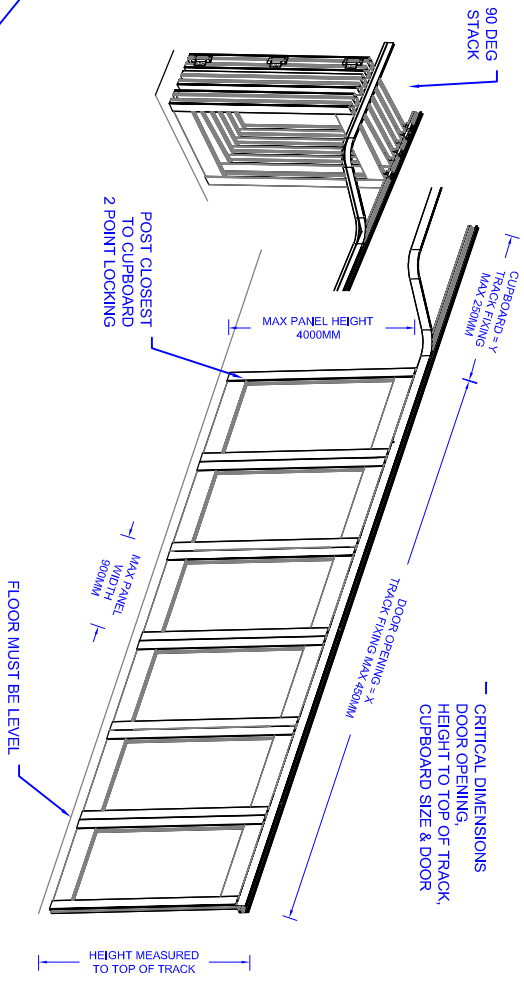
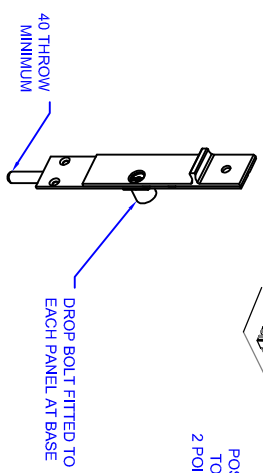
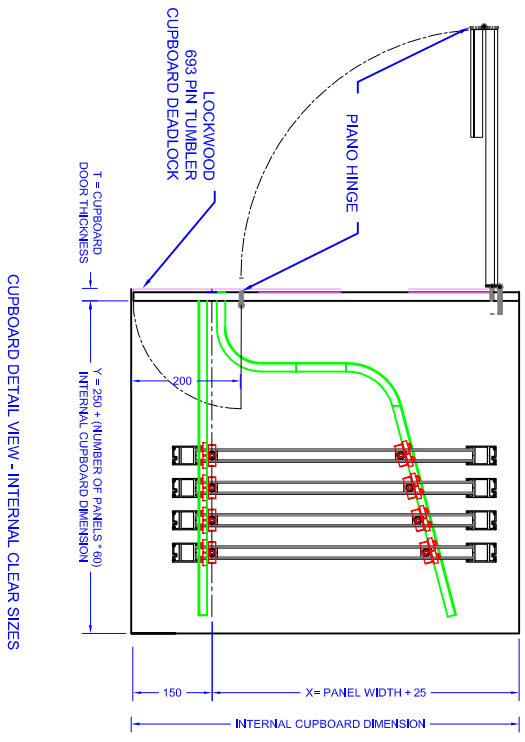
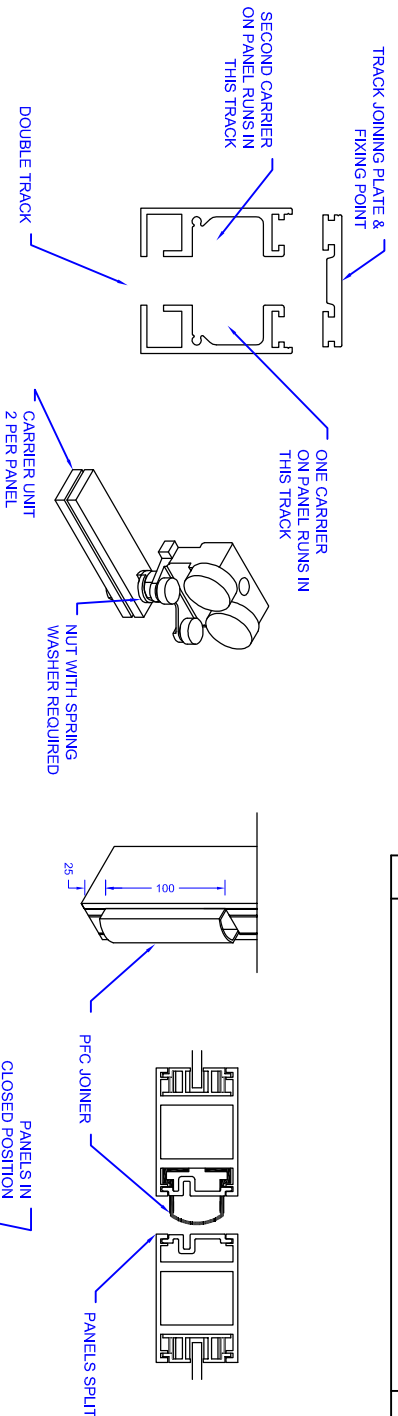

"FOR FURTHER INFORMATION CONTACT
 MIRAGE ENGINEERING STAFF"

U.O.S. DIMENSIONS IN MILLIMETRES

CONFIDENTIAL NOTE: This drawing and its designs, specifications and engineering information disclosed hereon are the property of Mirage Doors (Aust) Pty Ltd and are not to be disseminated or reproduced without express written consent. The drawing is loaned in confidence and then only for consideration of the matter disclosed hereon. In accepting loan of this drawing, the recipient agrees to keep it and the matter disclosed hereon in confidence and not to use nor permit their use in any way detrimental to Mirage Doors (Aust) Pty Ltd.

Mirage Doors (Aust) Pty Ltd		PROJECT Fiesta	
ACN 601 182 629		STACKING DOORS	
PH 1 800 465 599		DETAILS	
DATE 08/03/2016	SCALE NTS	TITLE 90 DEG STACK	REV. SHEET 0 2/2
DRAWN J.R.	CHECKED	SIZE DRAWING NO.	
APPROVED & DATE		QLD-	
FILE FILENAME.dwg			