

TILT DOORS



The most prominent visual feature of your building, factory or shed is often the garage door. So it makes sense to choose our V-Line tilt door because it's the ideal combination of strength, security and aesthetic appeal.

FEATURES

- Spring balanced
- Small headroom and sideroom clearance requirements
- Steel frames

APPLICATION

As tilt doors are predominately used in private garages on residential homes or units, factors such as ventilation, strength, security and appearance are important. In a world of choice, we have endeavoured to cover all possible needs with its diverse and innovative product range.

The V-Line tilt door has successfully been used in garages for over 30 years. This range has proven to be the premier choice for superior strength and appearance.

Engineered using the latest roll-forming technologies, this door significantly increases the security of the basement lock-up garage. Often the forgotten feature of multi dwelling developments, this door will also significantly improve the appearance and marketability of your basement car park.

RECOMMENDED SPECIFICATIONS

Steel-Line Tilt Door, as supplied by Mirage Doors, Accent Mirage Doors and Rosssdoor.

OPTIONS

Choose between the following:

- Fully perforated Zinalume®;
- Bottom 900mm perforated;
- Bottom 450mm perforated;
- Fully perforated Colorbond® with perforated head panel;
- Fully perforated Colorbond® with solid head panel;
- Solid Colorbond®;
- Top and bottom part perforation;
- Top 450mm perforated.

FINISHES

- Zinalume® or a wide range of Colorbond® colours;
- Solid sheet or fully perforated, offering up to 65% airflow.



MINIMUM HEADROOM IS SHOWN / PANEL THICKNESS CAN CHANGE DEPENDING ON THE DOOR DESIGN

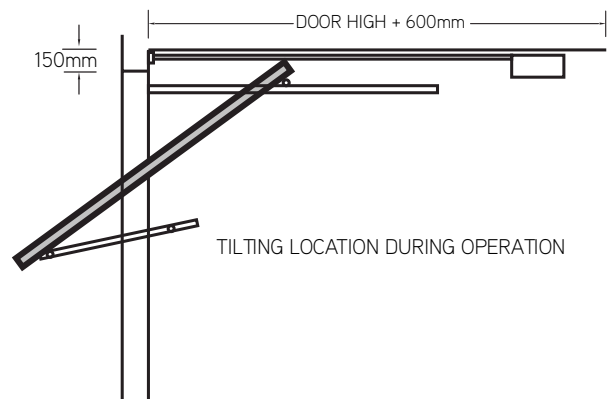
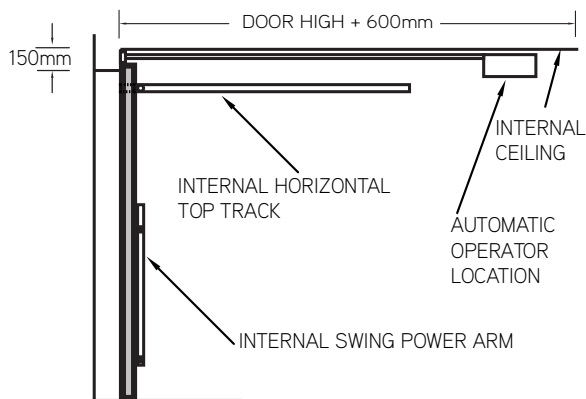

PLAN VIEW

Grey shaded areas denotes head & jamb noggins by builder

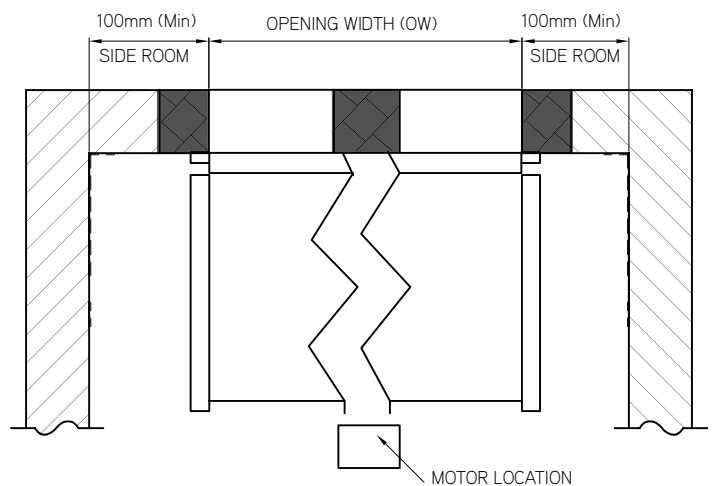
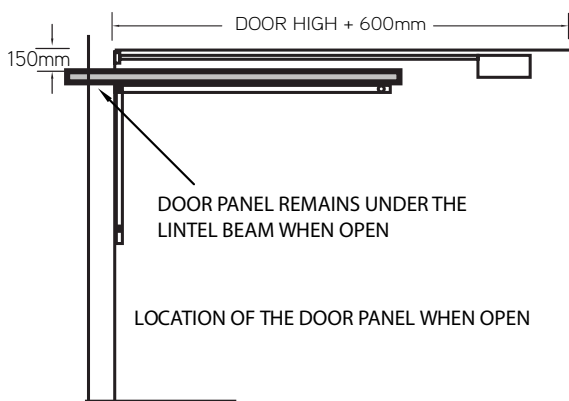

Mirage has a continuous program of product development and reserves the right to change specifications at any time without notice.