

SD 200/SD 300 FOLDING CLOSURE

SUITS STRAIGHT LINE AND CORNER APPLICATIONS



The SD 200 and SD 300 folding closure comprise a series of vertical panels; fitted with either glass, polycarbonate, aluminium or steel.

RECOMMENDED SPECIFICATIONS

The SD 200 and SD300 folding closure, as manufactured by Mirage Industries Pty Ltd., Australia.

APPLICATIONS

Suitable for, shopfront tenancies, airports, pharmacies, hotels, reception areas & free standing kiosks.

GLAZING OPTIONS

3mm toughened glass;

3mm polycarbonate;

Solid aluminium;

Multivent perforated steel sheeting (perforations are 4.5mm diameter, providing 51% ventilation)

OPERATION

Operation is manual by hand. The doors can be bi-parting or can stack to one side as required. Refer to the technical data sheets for sizes of the stacking spaces.

TRACK SYSTEM

An overhead track system is used. The track is an aluminium extrusion 35mm wide x 41mm high. Tracks may have a radius of no less than 600mm to suit curved applications. For elliptical curves, a template must be provided by purchaser.

PANEL SIZES

The panel widths are 285mm overall for SD300 and 200mm overall for SD200. Panels will fold in a concertina style formation.

Call 1800 465 599 or visit www.miragedoors.com.au

 **MIRAGE**
DOORS

MAXIMUM SIZES

The product has a maximum height of 4200mm and can span any width of opening. For minimum heights, please discuss with your local Mirage Doors representative.

LOCKING

As standard, the leading posts will be provided with Lockwood style cylinders which can be operated from both sides. The lock is supplied with a 'builders key' which enables the client to change over the cylinder to their own requirements. Please note that masterkeying is the responsibility of the purchaser or their client.

Floor-mounted sockets with spring loaded dust caps will be included.

FINISH

The standard finish is matt natural anodised aluminium.

A powdercoat finish is available at additional cost and lead time.

COMPACTION

Typically the panels will compact to between 16% -20% of the opening size for SD200, and 13%-17% of the opening size for SD300, depending on the locking post configuration.

BOTTOM RAIL

WEIGHT

The door weighs approx. 14kg/m²

WORK BY OTHERS

Unless other wise specified:

- Preparation of all opening walls and floors to receive the folding closure;
- Provision of timber or steel supports, access panels, or any joinery work.

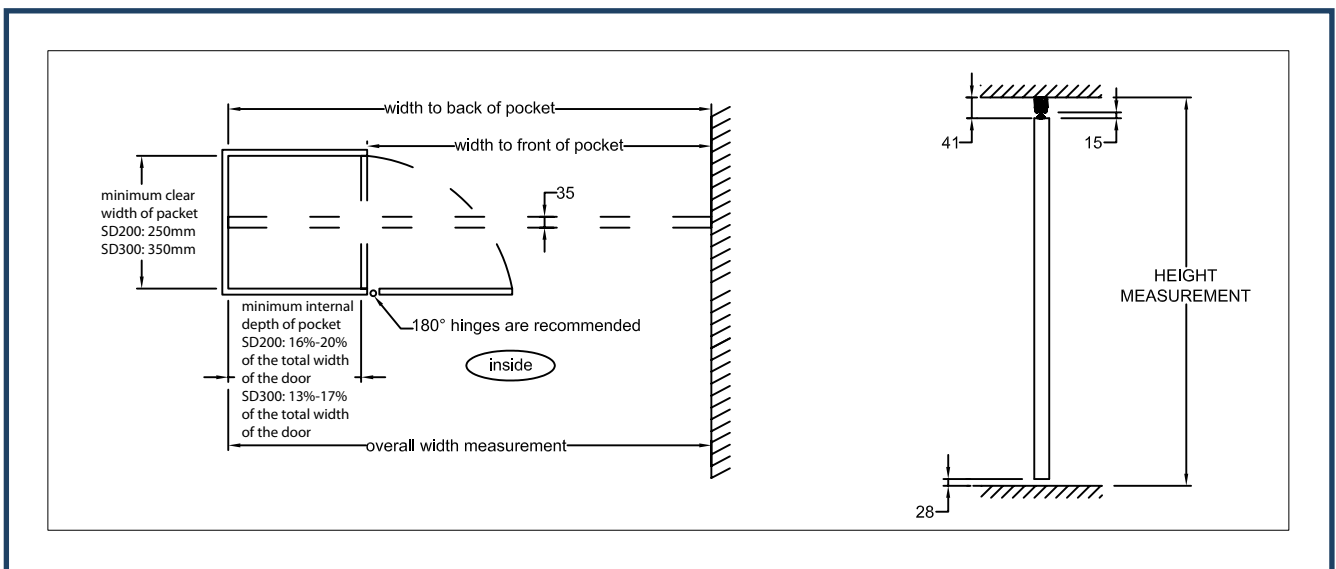

Mirage has a continuous program of product development and reserves the right to change specifications at any time without notice.

Call 1800 465 599 or visit www.miragedoors.com.au

