

SERIES 57 ALUMINIUM TRUCK SHUTTERS

"ROBINSON" SHUTTERS ENGINEERED IN SEARCH OF EXCELLENCE

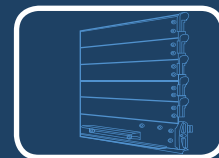

57mm Single Skin Slats create a shutter which is exceptionally easy to operate with the advanced design minimising maintenance.

RECOMMENDED SPECIFICATIONS

Series 57 Aluminium Truck Shutter, as manufactured by Mirage Industries Pty. Ltd., Australia. Product Code AE/ROB/57.

APPLICATIONS

Suitable for tool boxes, medium size delivery vans and large trucks that require an easy and quick form of access.

FINISH

Available in matt natural, anodised and a range of powdercoated colours.

SIZES

A single door is available to suit an opening up to 2.6 metres high by 2.5 metres.

STANDARD CURTAIN

Made of single skin aluminium extruded slats. Each slat has a flat face of 57mm and is 1.15mm thick. Both ends of every aluminium slat are fitted with a solid interlocking nylon clip that secures slats laterally and takes up wear. When assembled these slats create a modern flat surface perfect for sign writing.

ROLLER DRUM

The drum is manufactured from 100mm diameter extruded aluminium tube, solid nylon end caps and a solid steel shaft. Helical oil tempered springs are completely concealed and supplied pre-tensioned for fast installation.

Call 1800 465 599 or visit www.miragedoors.com.au



CHANNEL GUIDES

1.6mm thick folded Zinalume® (22mm deep x 23mm wide). An extruded aluminium side guide is available as an optional extra (24mm deep x 45mm wide).

BRACKET OPTIONS

All bracket styles have the channel guide pre-fixed for smooth operation and ease of installation.

Fixed Position Front Roll Bracket - The most basic and simple design. Top slat is bolted directly to drum.

Pennant Plate Front Roll Bracket - Drum slides in bracket to provide minimum clearance from the header plate at all times. Top slat is bolted directly to drum.

Minimum Radius Front Roll Bracket - Designed to take up the minimum amount of headroom. Top slat of the curtain is connected to the drum via cables.

Roof and Rear Roll Bracket - The drum is mounted in a fixed position to the rear of the roof cavity. The top slat of the curtain is connected to the drum via cables.

Roof Cable Front Roll Bracket - The drum is mounted in a fixed position. Bottom rail of the curtain is connected to the drum via cables.

BOTTOM RAIL

The bottom rail is extruded aluminium section fitted with a rear aluminium cover plate designed to cover the locking device. Comes standard with heavy duty finger pull extrusion, nylon end shoes and rubber seal. Stop brackets bolted to the inside of the bottom rail eliminate damage to header plate.

LOCKING OPTIONS

- Hasp and Staple
- Flush Fitting Key Lock
- "T" Handle - Key locking or non-locking
- Lift Bar Rail - Incorporating flush key locking or non-locking
- Sliding Shoot Bolts

SEAL OPTIONS

Small Top Seal - Anodised aluminium extrusion incorporating 13mm brush.

Heavy Duty Top Seal - Anodised aluminium "J" gutter extrusion incorporating brush seal in 30mm.

Side Seal - Aluminium extrusion incorporating rubber side seal.

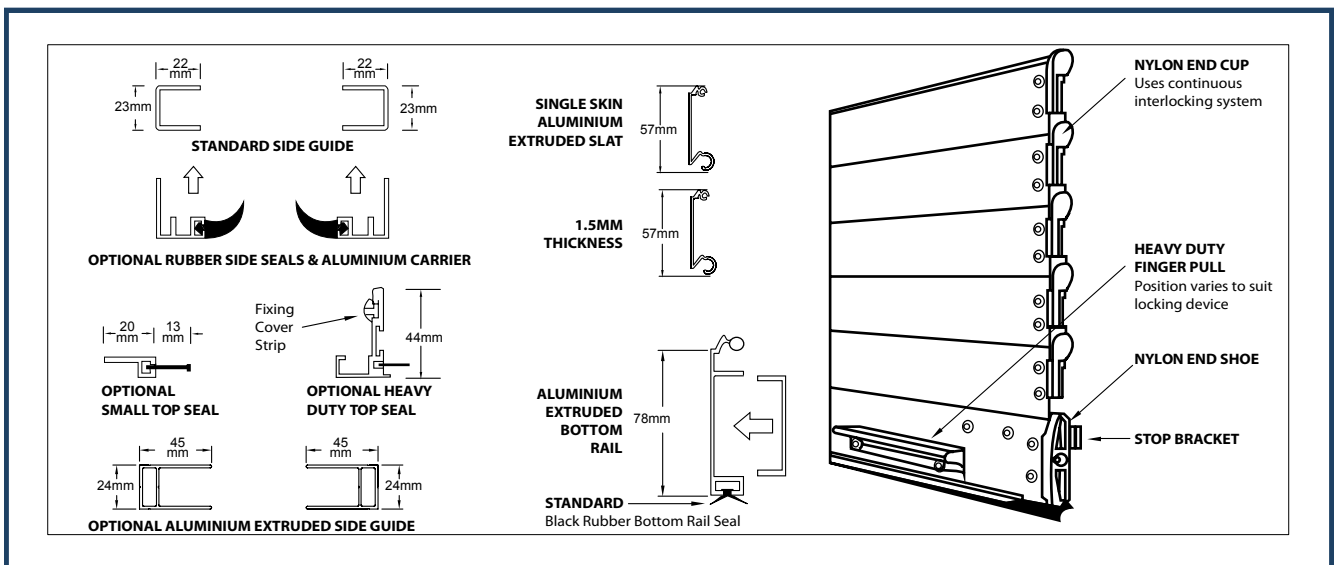

Mirage has a continuous program of product development and reserves the right to change specifications at any time without notice.

Call 1800 465 599 or visit www.miragedoors.com.au

 **MIRAGE**
DOORS