

# SERIES 35 MINI SLAT SHUTTERS

EXTRUDED ALUMINIUM INTERLOCKING MINI SLATS

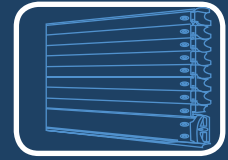

Mirage Series 35 Mini Slat Shutter has a small roll-up diameter and very easy operation due to the unique one-piece bracket and guide channel.

## RECOMMENDED SPECIFICATIONS

Series 35 Mini Slat - Aluminium Extruded Roller Shutter as manufactured by Mirage Industries Pty. Ltd., Australia. Product Code AE/MINI/35.

## APPLICATIONS

This mini slat shutter is designed to be used for smaller openings such as fire hose reel cabinets in shopping centres, equipment cabinets, cupboards and small architectural openings.

## STANDARD CURTAIN

Made of single skin aluminium extruded slats. Each slat has a flat face of 35mm and is 1.2mm thick. Both ends of every aluminium slat are fitted with a solid interlocking nylon clip that secures slats laterally and takes up wear. When assembled these slats create a modern flat surface which is perfect for sign writing.

## SIZES

A single door is available to suit an opening up to 2.2 metres high by 2.0 metres wide.

## BRACKETS

Fixed Position Front Roll with Pre-fixed Guide Channel.

The Zinalume® bracket head is pre-fixed to the top of the aluminium guide channels by a solid mild steel support. This makes for an easy & fast installation. Header or fascia must be a minimum of 345mm high so as to allow for the bundle diameter and the bottom rail.

## CHANNEL GUIDES

45mm x 24mm wide extruded aluminium section pre-fixed to the Zinalume® bracket.

Call 1800 465 599 or visit [www.miragedoors.com.au](http://www.miragedoors.com.au)



## ROLLER DRUM

The drum is manufactured from 100mm diameter extruded aluminium tube, solid nylon end caps and a solid steel shaft. Helical oil tempered springs are completely concealed and supplied pre-tensioned for fast and easy installation.

## OPERATION

Operation is by hand, with a pull-down rod being supplied if the shutter is too high to reach.

## LOCKING

Often these shutters do not require a locking mechanism but if required, Mirage can install a flush mounted lock inside the bottom rail with cylinder operated sliding latch and steel shoots to side guides.

- Single sided locking (outside or inside) (with or without a rear snib release).
- Two way locking (outside or inside).
- Sliding pad-bolts to each end of bottom rail (padlocks supplied by others).
- Lockwood cylinder keyed to one side only. Designed to enable the 'client' to master key to there requirements by others.

Please note that this cylinder protrudes from the face of the bottom rail by up to 25mm.

## BOTTOM RAIL

The bottom rail is extruded aluminium. It is designed to house most of the locking mechanisms offered and has a metal cover strip to the rear.

## FINISH

Standard colour is anodised matt natural. Other colours and powdercoat finishes are also available on request.

## INSTALLATION AND CLEARANCE DETAILS

Printed installation are available on request. Bundle roll-up diameters for different height doors are as follows:

Height	600	800	1000	1200	1400	1600	1800	2000	2200
Diameter	170	185	195	205	215	220	235	240	250

Note - Minimum headroom required is 345mm

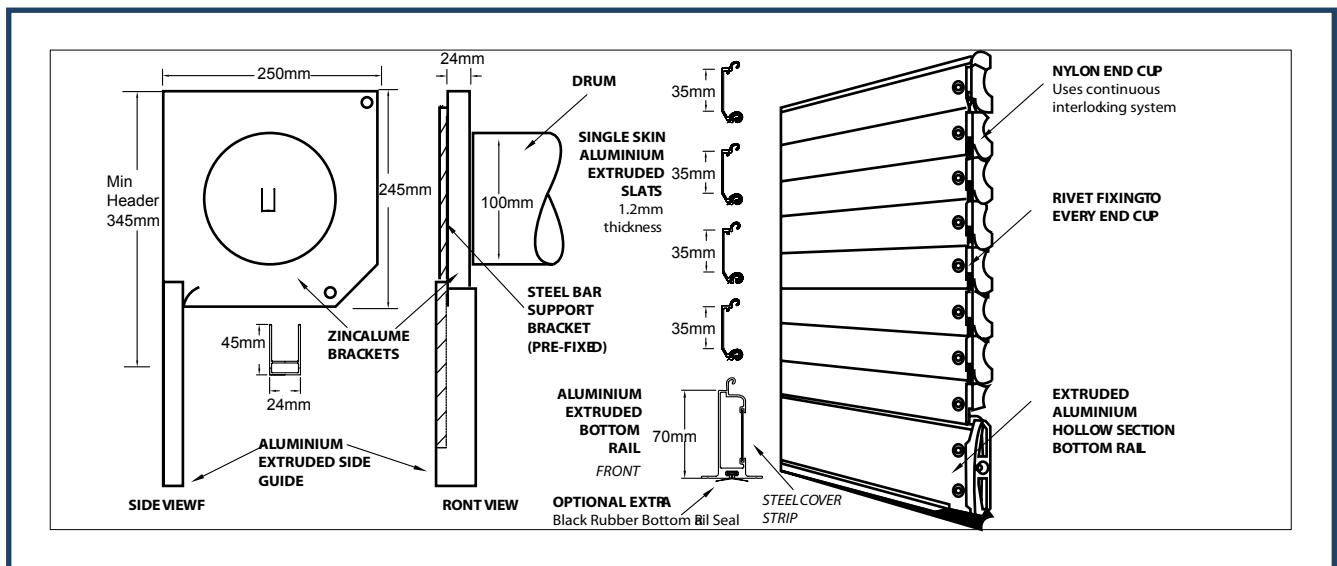

Mirage has a continuous program of product development and reserves the right to change specifications at any time without notice.

Call 1800 465 599 or visit [www.miragedoors.com.au](http://www.miragedoors.com.au)

