

## FIRE RESISTANT ROLLER SHUTTERS

DESIGNED, BUILT AND TESTED IN AUSTRALIA



### FEATURES

- Certified Integrity for 1, 2, 3 or a maximum 4 hours;
- Interlocking steel slats 100mm wide x 1.0mm gauge;
- Sizes up to 36m<sup>2</sup> overall curtain size (refer overleaf for details on size limitations);
- Controlled descent mechanism, activated by a fusible link and / or hold - open magnet;
- Sealed bearing drum assembly.

### APPLICATIONS

- The Mirage Fire Resistant Roller Shutter may be installed in a wide variety of applications where fire protection may be required, such as reception counters, corridors and store rooms.
- The shutters may also be used as secondary protection for other doors and windows.
- Typical locations include hospitals, car parks, hazardous goods storage, shopping centres, nursing homes, office buildings, factories, warehouses and tertiary institutions.

## RECOMMENDED SPECIFICATIONS

S100 Non Insulated Fire Resistant Steel Roller Shutters as manufactured by Mirage Doors. In accordance with A.S.1905-2-2005 and our C.S.I.R.O. Letter of Opinion. These shutters can be rated either to 1, 2, 3 or 4 hours e.g. a four hour "Fire Resistant Level" (FRL) would be -/240/10.

## SLATS

Slats are 100mm high and 1.0mm gauge. Malleable iron end clips are fitted every alternate slat.

## DRUM

The drum shall be manufactured from seamless steel tube and attached to end caps. Helical coil oil tempered springs will be fitted to an axle inside the drum tube. The drum shall revolve on steel bearings. Drum deflection shall not exceed 1/360th of the drum span.

## SIZE LIMITATIONS

**STANDARD:** Mirage fire resistant shutters up to our tested size of 2400mm wide x 2200mm high will be certified as manufactured (and installed if applicable) in accordance with Australian Standard AS 1905.2 - 2005.

**NON - STANDARD:** Under a Letter of Opinion from the CSIRO, we are permitted to manufacture fire resistant shutters up to 8000mm wide and 7000mm high to a maximum overall curtain size of 36m<sup>2</sup> (the letter of opinion states 40m<sup>2</sup> but we are restricted to 36m<sup>2</sup> due to limitations in the drum design and motors with descent mechanisms). For these shutters Mirage Doors shall forward our Test Certificate and Letter of Opinion to the purchaser, and (subject to respective state regulations), certification of these oversized shutters may be not from Mirage Doors but by a 3rd party at the purchasers expense. Refer to your local Mirage office for clarification.

## GUIDES

Guides must be fixed to a non – combustible surface (e.g. 190mm core – filled masonry, concrete panels upwards of 150mm thick or double skin solid brick - hollow brick is not suitable). Please refer to the Technical Data Sheet 9F, 9G & 9H regarding guide sizes.

## COMPLIANCE TO WINDLOAD SPECIFICATIONS

Fire shutters are not designed for and therefore will not comply with windload specifications.

## BRACKETS

The brackets are fabricated from mild steel and must be installed to a structural non - combustible surface.

## BOTTOM RAIL

50mm x 50mm dual duragal angles fitted both sides of the curtain.

## LOCKING

Not available

## OPERATION

The shutter shall be held open via a fusible link. Where interfacing with a smoke detector or fire alarm system is required, the fusible link shall also incorporate a hold – open magnet. Provision of the interfacing work is by the fire control subcontractor. When the daylight opening exceeds 4000mm in width, an additional fusible link is to be provided, located at the other end and connected via a cable to the fusible link on the gear side.

- Chain operation (up to 16m<sup>2</sup> overall curtain size);
- Electric operation is by a 3 phase motor. This includes emergency chain operation in the event of power failure. Keyswitches can be added if required. All wiring of Mirage electrical components, and provision of a suitable power supply (3 phase 415v with neutral, terminated to a Clipsal WHT 20 isolation switch within 1 meter of the motor) is by others.

## FINISH OPTIONS

- Galvabond steel (standard)
- Polyester powdercoat colours (selected from manufacturers powdercoat colour charts). Please note that an extended warranty is not available when metallic powdercoat is applied to steel surfaces) Note that Metallic or Pearl powdercoat finishes are not recommended for roller shutters.

## INSTALLATION AND CLEARANCE DETAILS

Refer to Technical Data Sheet 9F, 9G & 9H for general information.

## TIPS FOR ARCHITECTS, SHOPFITTERS & BUILDERS

- Preparation of openings to suit the fire resistant roller shutter is by others;
- The shutter must not be installed to hollow stud walls. Refer to the Technical Data sheets to ensure adequate opening preparation;
- If required, provision of jambs, cladding of columns, bulkheads and ceiling slot adjustments are by others;
- If a 30 minute insulation rating is required, this can only be achieved via inclusion of sprinklers and / or drenches. This is outside our scope of authority and expertise, and is explicitly excluded from our product offering and certification responsibility.

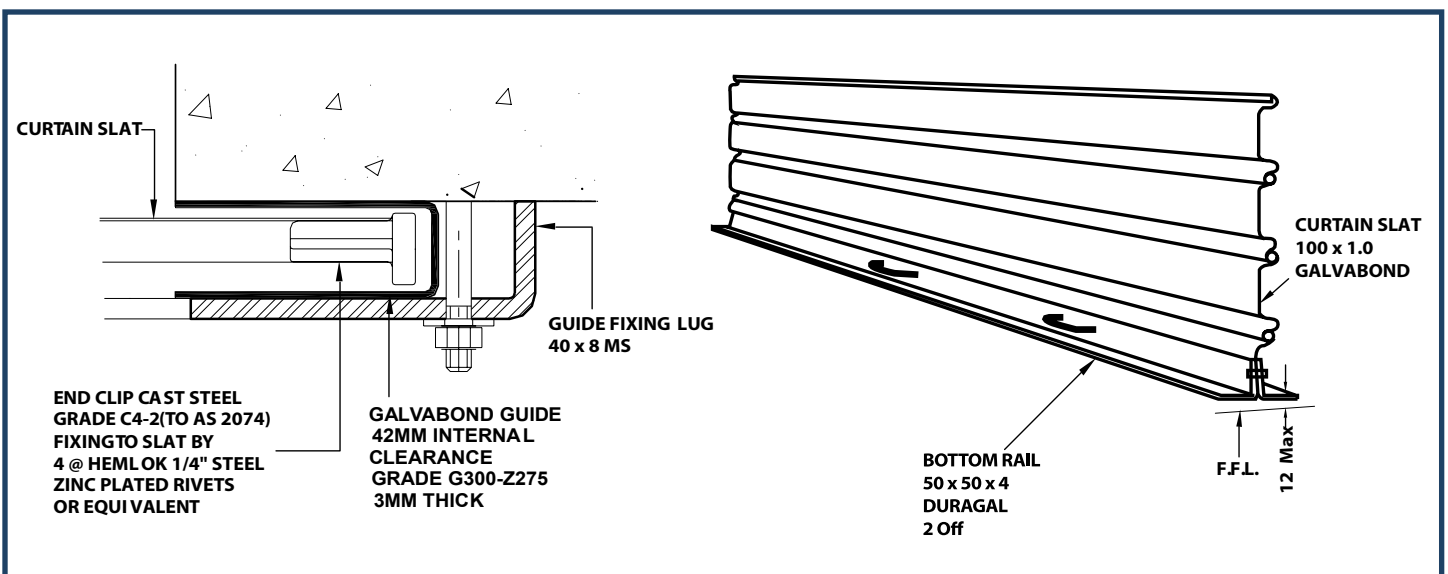

Mirage Doors has a continuous program of product development and reserves the right to change specifications at any time without notice.